

CAMPSNA: A Cloud Assisted Mobile Peer to Peer Social Network Architecture

Yuan-ni Liu Hong Tang, Guo-feng Zhao
The School of Communication and Information Engineering of ChongQing
University of Posts and Telecommunications. China
liuyn@cqpt.edu.cn



ABSTRACT: *In the social network, people with same interest construct a group, where people can share their interesting contents. With the popularity of the mobile devices, mobile users can connect to the internet for services such as downloading videos, music and pictures anywhere at any time, which may cause heavy traffic burden on the core network. The service content (eg. video, picture, music) downloaded and shared in the same social network interest group may always be similar, which may lead to repeated traffic transmitted in a short time period; on the other hand, the size of the service content may be very large for a single user, which will take it along time and spend much money to finish a complete service request or sharing. It is necessary to study how to reduce the requests in internet from the mobile users to reduce the flow on the core network, as well as reducing the economic cost and the service time, which is the main motivation of our research. Based on the universal mobile social network architecture, this paper proposed CAMPSNA: a cloud assisted mobile peer to peer social network architecture. In which, the cloud center is introduced to help the mobile devices offloading complex tasks to the cloud. The end devices in the architecture construct a local mobile peer to peer network to share their existing content based on their social relationships to reduce the burden of the cloud center.*

Subject Categories and Descriptors:

C.2.4 [Distributed Systems]: Distributed Applications; **H.3.3 [Information Storage and Retrieval]:** Information Search and Retrieval

General Terms: Mobile Cloud Computing, Peer to Peer Net-

work, Social Network

Keywords: Mobile Cloud, Mobile peer to peer Network, Social Network, Network Architecture, Data Exchange

Received: 11 November 2013, Revised 13 February 2014, Accepted 19 February 2014

1. Introduction

Recently, social network has gained a lot of attention, in which the relationships of the users are defined [1]. The social network relationships [2] have been widely used in the services such as data exchange, sharing, delivery sharing, video downloading to improve the network services efficiency and effectiveness. As the popularity of the mobile devices and the enhancement of the functions, mobile social network users may obtain diverse services (i.e., video, movie, music, pictures) from the internet anywhere at anytime. The growing service demands and the downloading traffic greatly increase the burden on the internet. As people in the same interest group may always focus on the similar thing, the content they request from the Internet may always be the same. It is useful to respond only one of the requests from the users in a interest group to ease the traffic and service requests of the Internet by some way. On the other hand, it is costly and time-consuming for a single user to finish the entire downloading of a movie, video, etc.

Mobile social network [1] [3] [4] [5] [6] [7] combines the features of mobility and co-relationship together, in which the social relationships can be used to improve the

efficiency of content publishing, data exchange, sharing, and delivery services. The content shared according to the social relationships is always through the internet, which will result to considerable traffic on it. And because of the capability and the battery power, it is necessary to save the time of a service and to mitigate the complex task of the end system.

Mobile peer to peer network comes out to facilitate the exchange of personal information, or support us in more complex tasks trading delivery tasks. But due to the capability and battery technology of the mobile devices, the complex tasks as scheduling the files sharing and the communication protocols in the mobile peer to peer network would always be problems. Therefore, it should offload the data and complex computing tasks from mobile devices, which is the main reason that the Mobile Cloud Computing [8] [9] comes out.

Taking the above problems into consideration, this paper proposed CAMPSNA: a cloud-assisted mobile peer to peer social network architecture. In the architecture, the cloud migrate the Internet services on it, and divides the mobile users into different interest groups, as well as the complex tasks computing and managing, monitoring the states of the mobile users. The users construct a mobile peer to peer social network, and they only need to send service requests to the cloud and execute the downloading action. The main feature of our architecture are as follows:

- (1) By localizing the service content that end user required to the cloud computing center, the numbers of the service demands are moved from the core network to the cloud center, which reduced the core network traffic.
- (2) The cloud divided the mobile users into different interest groups by their service information and their own information, and the users in the same interest group can collaboratively complete the service content downloading tasks, which shorten the service time of the user and reduce the economic cost of a service demand.
- (3) The end users construct a local mobile peer to peer network to distribute their existing service content, which reduce the load of the cloud center.
- (4) The only thing that the end devices need to do is to send request to the cloud and distribute the service contents to its peers, and the complex computing tasks are shifted to the cloud, which mitigate the load and save the energy of the terminals.

The rest of this paper is organized as follows. Section 2 gives a brief description of the CAMPSNA architecture. Detailed design issues are discussed in section 3. The basic scenarios as interest grouping dividing, downloading task assign and downloading node choosing are analyzed and discussed in section 4. The conclusions and future works follow in section 5.

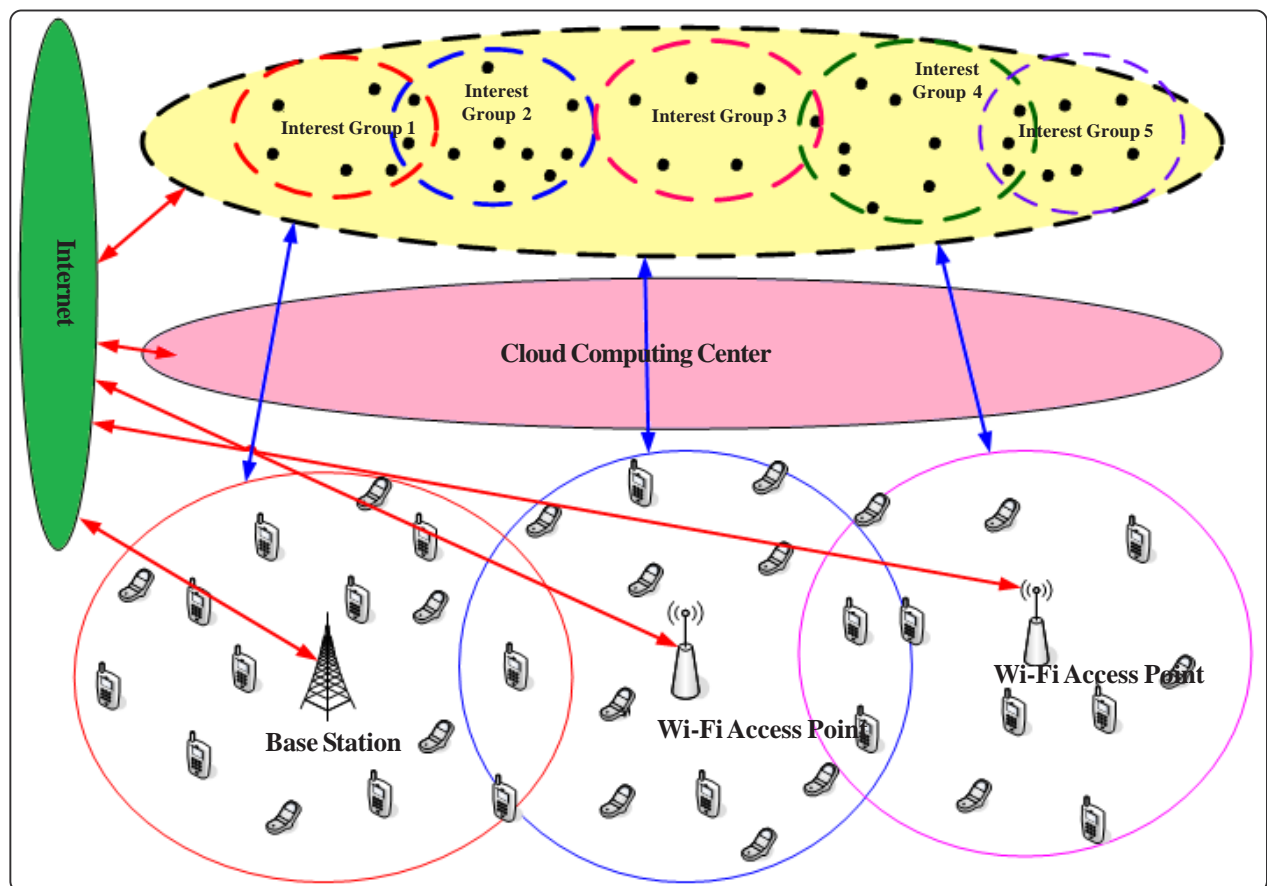

Figure 1. CAMPSNA architecture

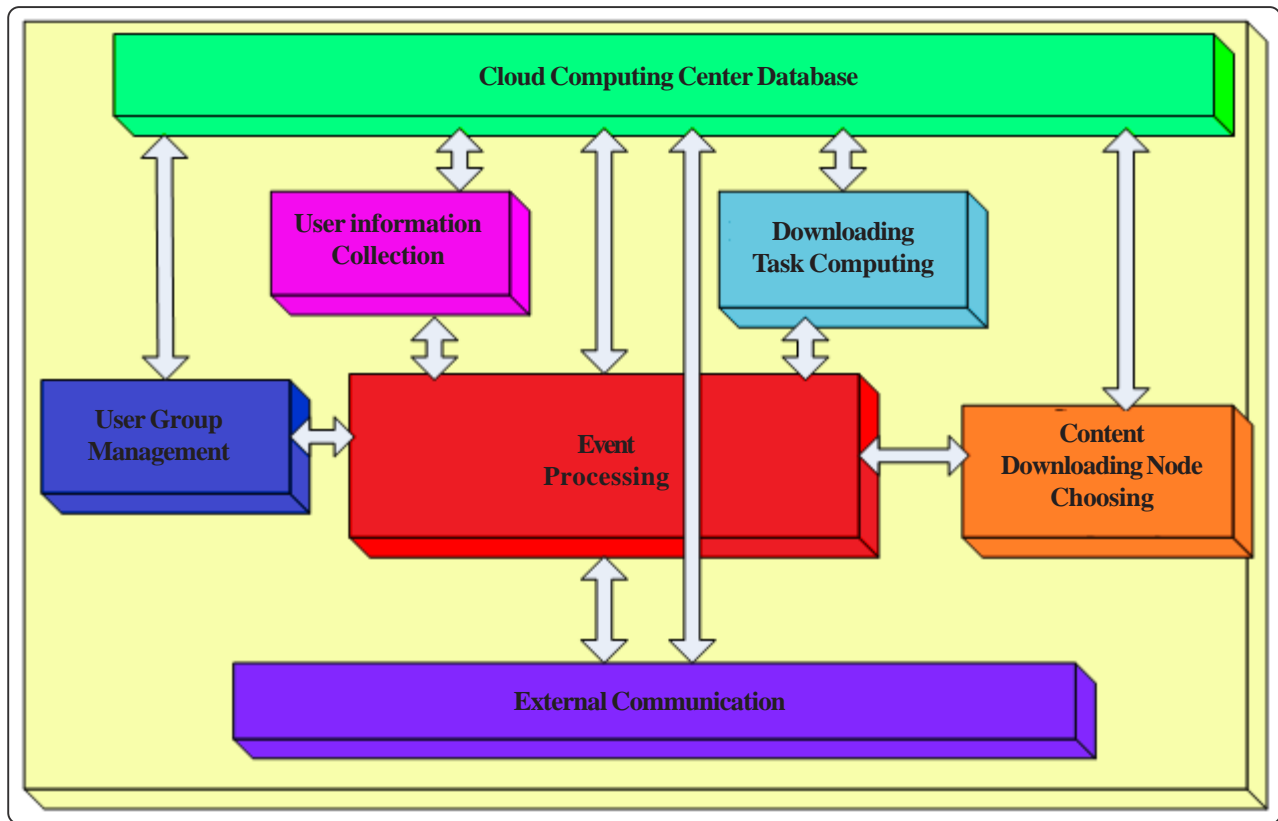

Figure 2. The main modules of the CCC

2. CAMPSNA overview

2.1 Assumptions

For simplicity, the following assumptions are made regarding CAMPSNA architecture shown in Figure 2:

1. In the network, everything is considered to be service, and we regard the downloading of the files, videos, movies, music, picture provided by the network as services.
2. There should be many cloud centers located in different places providing services for the mobile users and the clouding centers can interact with each other, which will be considered as our future work. In this paper, we assume that there is only one cloud computing center.

2.2 The Overview Objective

1. Minimize the number of the users' service requests to the core network as possible and the traffic on the core network.
2. Reduce the cost and time of a service for the users.
3. Enhance the capability of the mobile device, like the computing, storage capacities and the battery working time.

2.3 System Architecture

The CAMPSNA architecture is illustrated in Figure 1. In the architecture, the cloud computing center (CCC) connected to the Internet and the mobile peer to peer network. Different mobile devices compose a mobile peer to peer network, and they are divided into different interest groups according to their social relationships.

The main functions of the CCC include service handling, file migrating, storage and management, mobile users and devices information collection, interest groups dividing calculation, file splitting calculation, file downloading node calculation. The main function of the modules will be discussed in section 3.

The mobile users locating in different areas construct a mobile peer to peer network, in which users are classified into different interest groups by their own information (i.e. location, service name). Users in a interest group may have the same service request, which may request the sub-content of a service, and they can cooperate to complete a file downloading task and share the sub-content of the by a peer to peer mode.

3. The Main Design Issues for the Architecture

As shown in Figure 1, CAMPSNA involves functions in two planes: CCC plane and the user plane. In this section, we discuss several key design issues.

3.1 CCC plane

Figure 2 describes the main modules of the CCC. The CCC contains seven modules, and we will describe the functions of the each part.

3.1.1 Cloud Database module

The cloud database contains all the information of the services, user, interest group, and control information. The CCC should localize the services request by the mobile

users to mitigate the burden of the core network. The service information includes the service content and the service index information such as category, name, popularity, required frequency, etc. When a mobile user requests a service from the CCC, it should register its own information like location, the service name, and some cognitive information like the battery, mobile locus and so on. The CCC needs this type of information to classify the mobile users into different interest groups, and to assign the downloading task for the users in a same interest group to cooperate finishing the same service. Further more, the CCC needs other control information stored in its database to control the system working normally.

3.1.2 External Communication module

Through the external communication module, the CCC can request the internet or other CCC for different services, and it also can interact with mobile devices to enhance their capabilities.

3.1.3 User Information Collection module

The CCC need to collect the user information to provide services for them. When a mobile user asks the CCC for a service, the CCC needs to collect the information about the user location, interest, and the required service name. It also need to collect the information about the moving status, predicted position after some time period, the status of the mobile device battery by some cognitive way. With this information, the CCC may determine which interest group the mobile user belongs to, and how to assign downloading task of a service for the user.

3.1.4 Event Processing module

The event processing module is responsible for handling all the events triggered by the actions in a complete service processing time period. The main events include are as follows:

Event 1: Receiving a service request from a user. When a mobile user asks a service from the CCC, it will send a request message to the CCC, which will trigger this event to happen.

Event 2: A new user requires to join in an existing interest group. When the CCC detects, or a mobile wants to join an existing interest group, this event will happen, which will trigger the CCC to make further processing.

Event 3: Receiving a keep-alive message from a user. The CCC should monitor the mobile users' statues, as whether it stays in the physical range of the interest group. In this situation, the user should send keep-alive message to the CCC to keep its status periodically.

Event 4: A mobile user left normally. In the CAMPSNA, the user is mobile, and it will leave an interest group, so it will send a leave message to inform the CCC.

Event 5: A mobile user left abnormally. This event happens when the connection between the user and the CCC

because of the unstable wireless link, abnormal shutdown of the mobile device or the no electricity of the battery and other abnormal situations.

3.1.5 User Group Management Module

After an interest group has been set up, it is necessary to maintain the group and manage it, which is the main function of the user group management module. In the CAMPSNA, the users with the same interest may in the same interest group, and they can cooperate with each other to finish a large video downloading task or other tasks. Compared with the wired network, in the mobile peer to peer network, the users' location are changed frequently, and the wireless connections are unstable, as well as the continuously joining and exiting behaviors of the users, so it is very complex to manage the interest groups. The user group management module mainly deal with the issues of user joining or leaving, exit abnormally, monitoring the connection states between user and CCC, maintaining the interest group status, etc.

3.1.6 Task Computing Module

In the CAMPSNA, in order to save the cost and time of a service required by the user, users in the same interest group are working together to finish the tasks of downing of the service contents. In this way, the CCC will computing for the users in an interest group to assign the downloading task. To be fairly, the CCC should assign the downloading task reasonably, that to say, in the interest group, each user should undertake the downloading task and share the content with others. On the other hand, the user is mobile, so it may move out of the physical range of the interest group. The CCC should predict this by the user information and cognitive information, and assign downloading tasks to this type of users rationally. That is to say, it should assign the down task that the user can finish in that short time period, or finished the downloading task and shift to some other user before it moves out of the interest group. Further more, a user may join in two or more interest groups simultaneously, and the CCC also should realized this situation and assign the downloading task to it accordingly, and it also should computing the sequence of the downloading tasks referred to these interest groups.

3.1.7 Content Downloading Node Choosing Computing Module

After the users finished the downloading tasks (sub-content of a service) the CCC assigned to them, the users will require the rest part of a service. For each user, there may be one or more users own the service content the user lacks, and the content downloading node choosing the computing module will compute for the user to tell it where to downloading the lacking content. On the other hand, the service content is split into several pieces, and each user has one or more of them. The CCC maintains the information, and calculates for the user an optimal sequence downloading node sequence to save the entire service downloading time.

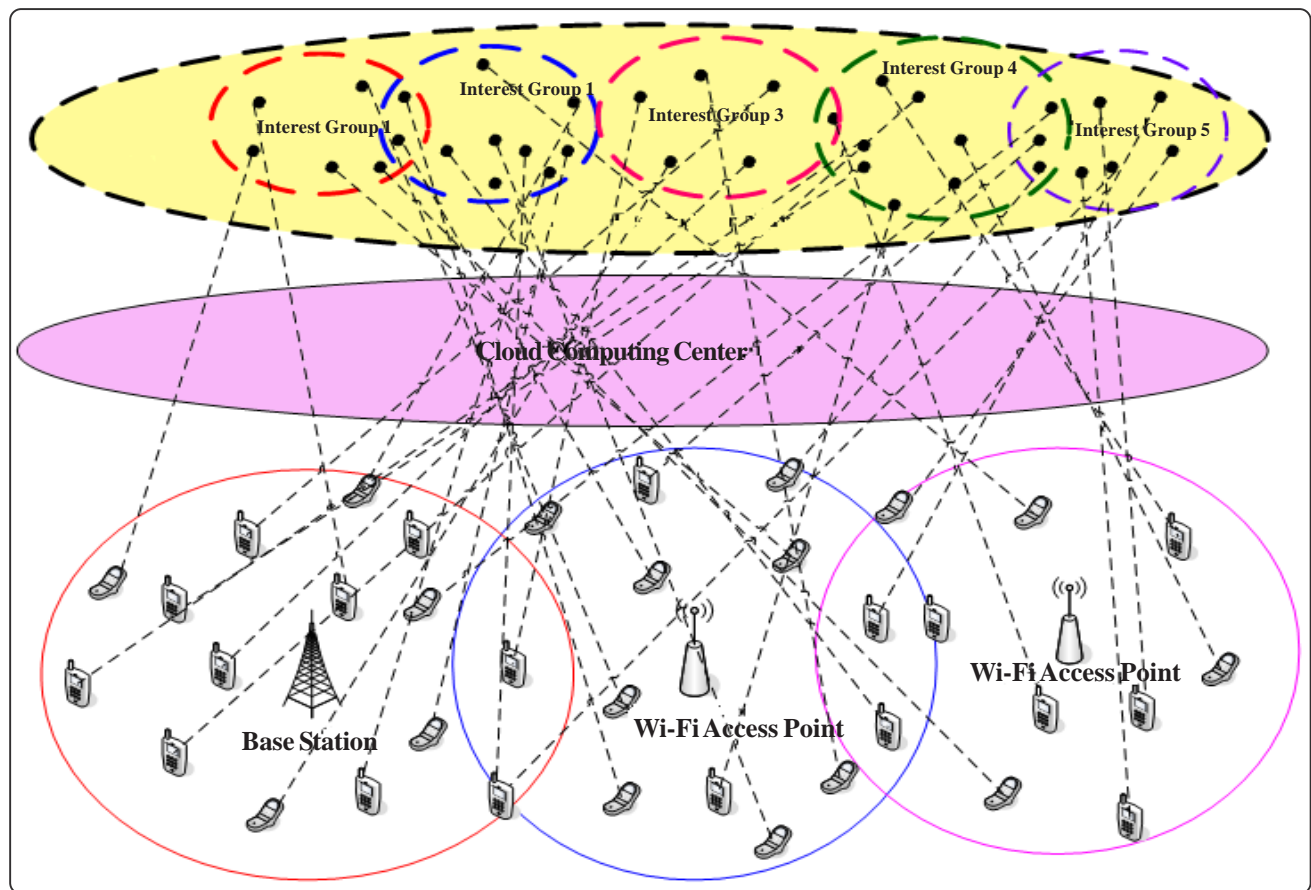

Figure 3. Interest Groups Dividing

3.2 User Plane

In the user plane, the users construct a mobile peer to peer network, and they were divided into different interest groups by their social relationships. The social relationships include the user interest, location and so on. The user in a interest group can work together to finish the downloading of a large service, and they can share their own pieces of the sub-service with each other to save the cost and downloading time.

4. System scenarios

In this section, we discuss several example scenarios and design considerations of CAMPSNA.

4.1 Dividing the users into different Interest Groups

In this scenario, the CCC needs to classify different mobile users into the correspondent interest groups according to the cognitive information received from the users.

As illustrated in the Figure 3, there are many mobile users linked to the Internet by the base station or Wi-Fi access point, and they also linked to the CCC. When a user connects to the CCC, it will report the cognitive information as the way it access to the Internet, the remaining battery power of the battery and the MAC address etc. to the CCC. The CCC will collect these information and the service information that the user requested, based on these information, the CCC can classify the users into five interest groups. The mobile users can construct into a mobile

peer to peer network, and they can share the service content in the same interest group. As shown in Figure 3, a user may join into two or more interest groups at the same time.

4.2 Assigning the Downloading Task

Users in the same interest group will always request the same service content. In the CAMPSNA, when the CCC receives the service request, it will migrate the service from the internet, dividing it into small pieces, and then assign the pieces to the users in the same interest group. The key problem is how to assign users with the pieces. At first, the size of the pieces may be different. Second, in order to be fairly, each user should participate in the downloading task, and the total downloading task for each user should be equal. Thirdly, because of the mobility of the users and the battery capability, there may be the situations that a user will leave a interest group or the battery will be without power before it finishing to download the service content or before it finishing to share the downloading content to other user in the interest group. Forth, as we have shown that a user may be in two or more interest groups at the same, which situation should also be considered by the CC when it assign downloading task to a user. Considering the above problems, the CCC will assign the downloading tasks to each user according to the power of their battery, the mobility mode of a user, the duration of a user in the interest group, the downloading tasks a user may participate in and other information, which are obtained by the cognitive or modeling.

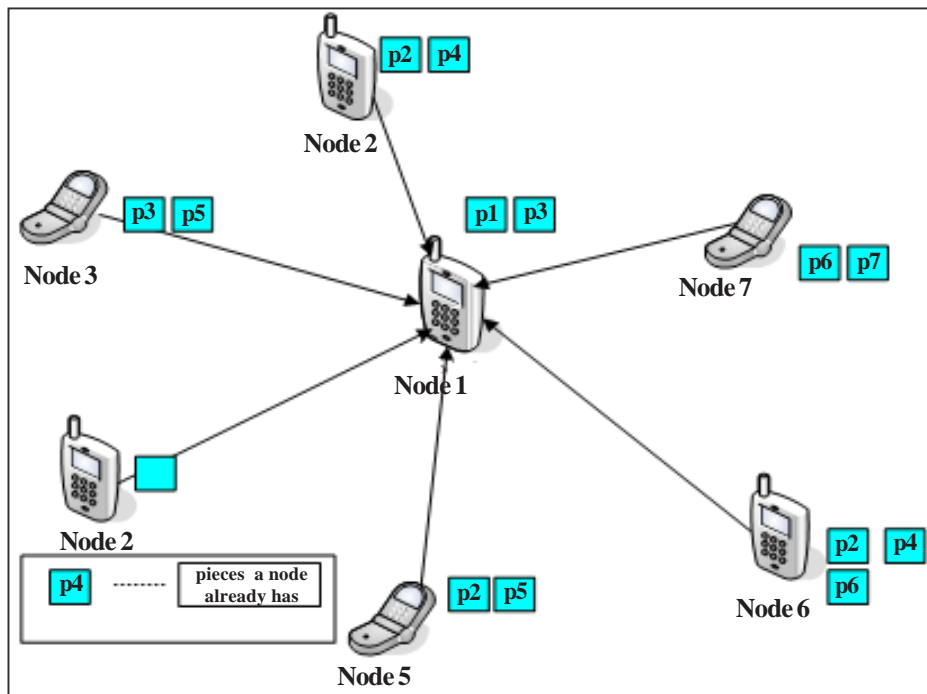

Figure 4. A bad solution of piece downloading

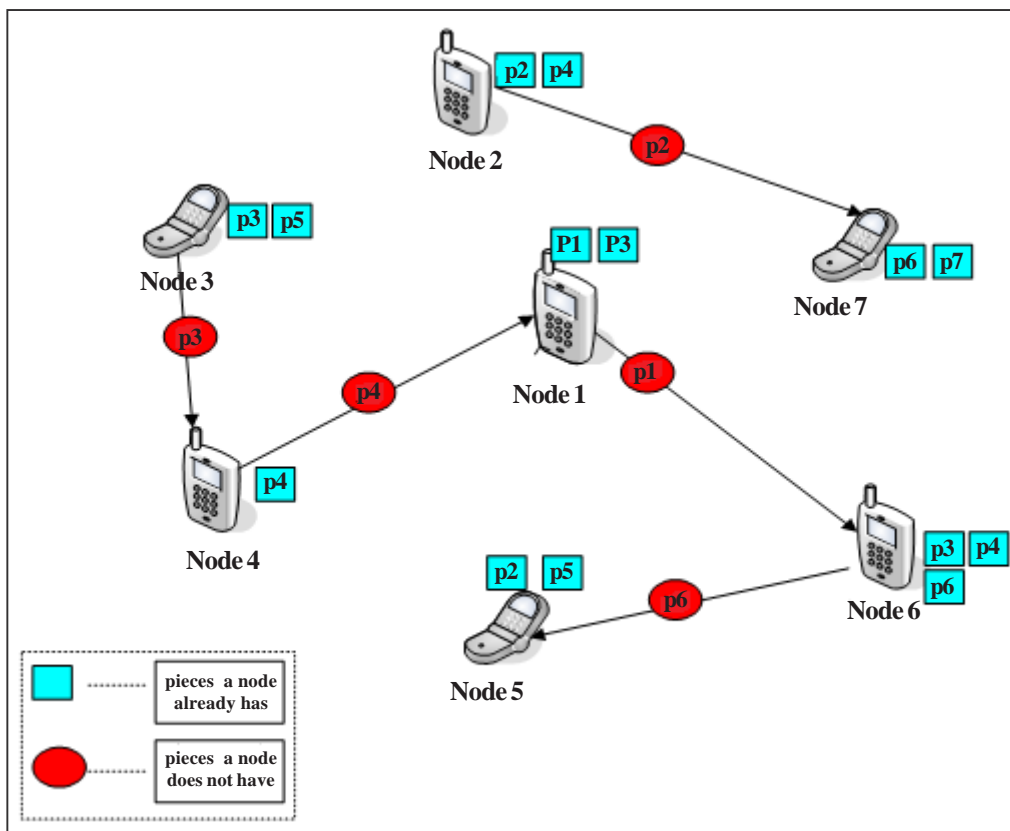

Figure 5. An optional solution of piece downloading

4.3 Computing the Downloading Nodes for a User

In the CAMPSNA, users in the same interest group will cooperate to finish the service content downloading, that is to say, a service is divided into several pieces, and each user only downloads one or more pieces of it. When one finishes the downloading pieces the CCC assigned, it will require the rest of the pieces it lacks from other

users in the same interest group. If the CCC do not calculate the downloading node for them, there will be downloading conflict occurred. There may be a lot of node require the same pieces from the same node at the same time, and the node will be unable to afford so many simultaneous connection.

Figure 4 illustrated the worst situation. In Figure 4, there are seven nodes working together to download a large service content, and the service content is divided into seven pieces: p_1, p_2, \dots, p_7 . As shown in Figure 4, node 1 has pieces p_1, p_3 , node 2 has pieces p_2, p_4 . Each node has part of the service content, and they will download the rest parts of the service from other node. The bad situation is, all the other nodes connected to node 1 to require piece p_1 . While the connectivity of node 1 is limited, it is unable to connect to the six nodes at the same time, so some node should wait a time period for piece 1 from node 1. The main reason for this situation is that the downloading sequence of a node for its lacking pieces is not planned well.

The CCC owns all the pieces information of a node, and it can do this work beforehand. Figure 5 gives an optional solution. In Figure 5, when the node require the rest pieces from the CCC, the CCC computes a optional downloading node for it according the pieces information of all the nodes in a interest group, avoiding downloading conflict as possibly. So, at some time period, node 6 downloads piece p_1 from node 1, node 5 downloads pieces p_6 from node 6, node 1 downloads piece p_4 from node 4, node 4 downloads piece p_3 from node 3, node 7 downloads piece p_2 from node 2. In this way, the downloading conflict will be avoided, and the average downloading time will be reduced.

5. Conclusion

In this paper, we have proposed CAMPSNA as a new cloud-assisted mobile peer to peer social network architecture for the mobile devices. We design the architecture in order to reduce the traffic on the core network, and save the cost and time of a large service content downloading. In the CAMPSNA, we separated the architecture into two main planes, CCC plane and the user plane. We proposed the CCC design modules, and the function of each module. We also introduced that the cooperating downloading in a interest group, and some referenced working scenarios were described.

For our future work, we plan to design the signaling messages and mechanisms for CAMPSNA. Other issues such as service file store and management, interest group set up, maintain and management, CCC computing algorithm, downloading task assign algorithm, downloading node choosing algorithm need to be designed. We plan to do further research on these areas related to CAMPSNA.

6. Acknowledgment

This work is partly supported by National Basic Research Program of China (2012CB315806), National Science and Technology Major Project of China(2012ZX03006001), Natural Science Major Foundation of Chongqing (CSTC.2012JJB40008), National Science and Technology Major Project (2012ZX03006001-004), Natural Science Foundation of Chongqing (CSTC.2012JJA40060), CQUPT Dr. Start-up Fund Research(A2011-48), Natural Science Foundation of CQUPT(A2012-83), Scientific and Technological Research Program of Chongqing Municipal Education Commission (KJ120504).

References

- [1] Nazir, F., Ma, J., Seneviratne, A (2009). Time critical content delivery using predictable patterns in mobile social networks, *In: Proceedings of the Computational Science and Engineering*, Vancouver, BC, Aug. 1066–1073.
- [2] Wasserman, Stanley., Faust, Katherine. (1994). *Social Network Analysis: Methods and Applications*. Cambridge, U.K.: Cambridge Univ. Press, Nov.
- [3] Kayastha, Nipendra., Niyato, Dusit., Wang, Ping. (2011). Hossain, Ekram. Applications, Architectures, and Protocol Design Issues for Mobile Social Networks: A Survey. *In: Proceedings of the IEEE*, 99 (12) 2130-2158.
- [4] Karki, Bishal Raj., Arto, Hamalainen, Porras, Jari. (2008). Social networking on mobile environment. *In: Proceeding of the ACM/IFIP/ USENIX Middleware Conference Companion*, p. 93–94.
- [5] Zhong Hao-bin, Bi Ling-yan, Feng Ze-wei, Li-Ning. (2008). Research on the design method of mobile social network services. *International Conference on Information Management, Innovation Management and Industrial Engineering*, Taipei, Dec. p. 458–461.
- [6] Kemp, John., Reynolds, Franklin . (2009). Mobile social networking: Two great tastes. *In: Proceeding of W3C Workshop Future of Social Network*, Jan.
- [7] Eyevibe. [Online]. Available: <http://www.eyevibe.net/faq.html>
- [8] Fernando, Niroshine., Loke, Seng W., Rahayu, Wenny. (2013). Mobile cloud computing-a survey. *Future Generation Computer System*, 29 (1) 84-106.
- [9] Gupta, Pargya., Gupta, Sudha. (2012). Mobile cloud computing: The future of cloud, *International Journal of Advanced Research in Electrical, Electronics and Instrumentation Engineering*, 1 (3) 134-145.